

## Imperial 40 lb. (22 L.) Electric Fryers



Model IFS-40-E Shown

### Model Numbers

- ☐ IFS-40-E

### Fryer Features

- 40 lbs. (22 L.) stainless steel frypots with radius formed edges.
- Unique serpentine element design ensure quick heat-up and recovery of oil.
- Elements are made of 304 stainless steel and rated at 14 KW.
- Frypot is robotically welded for consistency and leak prevention.
- Large "cool zone" captures food particles and keeps them from carbonizing in the fry zone.
- Snap acting thermostat has a 200°F - 400°F (93°C - 204°C) temperature range.
- Manual or optional programmable computer controls available.
- Two large nickel-plated wire mesh fry baskets with ergonomic, polyurethane coated handles.
- Fine mesh crumb screen.
- 1<sup>1</sup>/<sub>4</sub>" (32) full port ball valve for quick draining.

All measurements in ( ) are metric equivalents.

### Fryer Features

- Stainless steel frypot, front, sides, door, stub back, and basket hanger.
- 6" (152) stainless steel legs with non-marking feet. Plate mounted for secure support.
- One year parts and labor warranty. Limited warranty on stainless steel frypot is 5 years pro-rated.
- UL, NSF and CE listed.



### Imperial Commercial Cooking Equipment

1128 Sherborn Street ■ Corona, CA 92879 ■ 800.343.7790 ■ Ph: 951.281.1830 ■ Fx: 951.281.1879

www.imperialrange.com ■ E-mail: imperialsales@imperialrange.com

# Imperial 40 lb. (22 L.) Electric Fryers

Specification #:

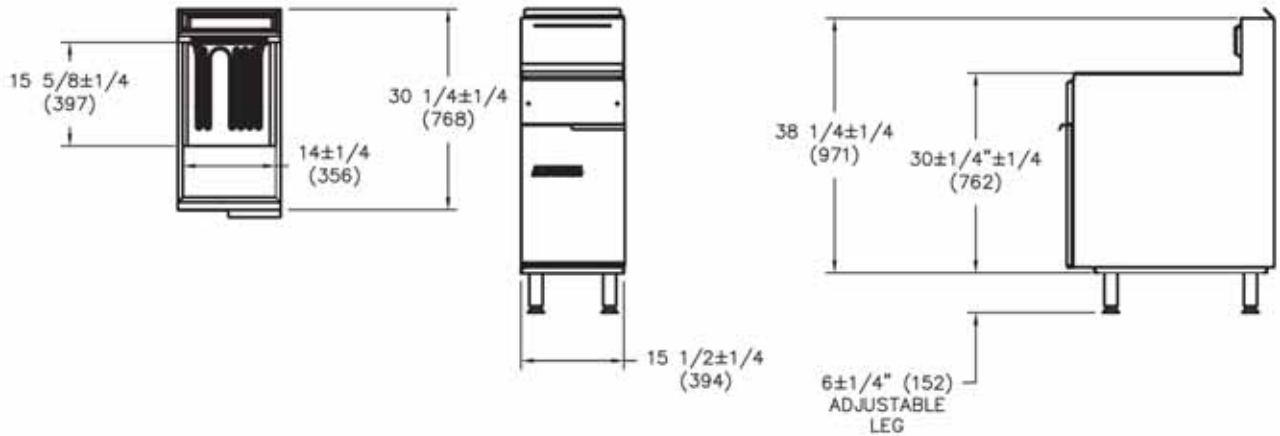

## 40 lb. (22 L.) Electric Fryers

Model#	Description	Oil Capacity		Electric Output KW	Ship Weight	
		Lbs.	(Liters)		(Kg.)	Lbs.
IFS-40	Stainless Steel Frypot	40	(22)	14	(100)	221

All measurements in ( ) are metric equivalents.

**Crated Dimensions:** 36" (891) d x 19 1/2" (495) w. Add 2" (51) to height of unit.

### Standard Exterior Finish Specifications

Front, sides, door, stub back and basket hanger shall be constructed of stainless steel with welded and finished stainless steel seams. Stainless steel legs shall be plate mounted and include non-marking feet.

### Frypot Specifications

All precision welded stainless steel vessel shall be constructed of heavy 16 gauge stainless steel. Vessel shall have a large foam area to prevent overflow. All vessel edges shall be radius formed for added durability. Frying area shall be 14" x 14" (356 x 356) with a 40 lbs. (22 L.) oil capacity.

Elements shall have a serpentine design to ensure quick heat-up and recovery of oil. Elements shall be made of 304 stainless steel and rated at 14 KW.

Snap acting thermostat shall have a 200°F - 400°F (93°C - 204°C) temperature range. Fail-safe high limit control shall shut off all gas if oil temperature exceeds 435°F. (224°C). Safety pilot shall be 100% shut off.

Large cool zone shall capture food and breading particles and keep them out of the frying area to improve food taste and prolong oil life. Fine mesh crumb screen shall be removable. Unit shall include removable drain pipe and clean out rod. Drain shall be a 1 1/4" (32) full port drain valve for quick draining.

### Electric Requirements

208 VAC, 3 PH, 60 HZ, 60 AMPS MAX.  
240 VAC, 3 PH, 60 HZ, 60 AMPS MAX.

### Clearance

For use only on non-combustible floors. Legs or casters are required for non-combustible floors; or 2" (51) overhang is required when curb mounted. Provide 0" clearance from non-combustible surfaces and 6" (152) from combustible surfaces.

### Optional Items

- Portable oil filter unit
- Fryer drain station with a storage cabinet
- Quick disconnect hose and restraining device
- Stainless steel joiner strip to cover between fryers
- Various size fry baskets
- 6" (152) swivel casters (front two casters are locking)
- Stainless steel backguard

### Optional Fryer/Filter Systems

- Pre-packaged systems with matching cabinet and built-in filter and pan
- Stainless steel dump station and food warmer
- System options include solid state thermostat control, computer fry control and basket lifts

AIA File #:

## Imperial Commercial Cooking Equipment

1128 Sherborn Street ■ Corona, CA 92879 ■ 800.343.7790 ■ Ph: 951.281.1830 ■ Fx: 951.281.1879  
www.imperialrange.com ■ E-mail: imperialsales@imperialrange.com