

Heavy Duty Electric Griddles Thermostat Controlled



Model ITG-36-E

Griddle Features

- Stainless steel front, sides and landing ledge.
- Welded stainless steel seams.
- Large 5" (127) stainless steel landing ledge.
- 4" (102) heavy duty stainless steel legs with adjustable feet.
- One year parts and labor warranty.
- UL, NSF and CE listed.



Model Numbers

Thermostat Controlled Electric Griddles

- ITG-24-E
- ITG-36-E
- ITG-48-E
- ITG-60-E
- ITG-72-E

Cook Top Features - Electric Griddle Top

- Thermostat maintains selected griddle temperature during peak cooking periods.
- Full width rear flue distributes heat uniformly across griddle surface.
- Unique element design ensures even heating over the entire griddle plate surface, with fast heat-up and recovery.
- Electric heating elements are solid mounted to the bottom of the griddle plate with 1" flat bar. 4 KW per foot of griddle plate.
- 1/2" (13) highly polished steel griddle plate maintains selected temperatures and assures quick recovery. Optional chrome griddle top also available.
- Full 24" (610) depth plate for more cooking surface.
- Stainless steel grease trough, one piece rolled front.
- Large grease can with 1 gal. (3.8 L) capacity. Weep hole indicates when can is full.
- 3 1/2" (89) wide grease gutter.

All measurements in () are metric equivalents.

Imperial Commercial Cooking Equipment

1128 Sherborn Street ■ Corona, CA 92879 ■ 800.343.7790 ■ Ph: 951.281.1830 ■ Fx: 951.281.1879
www.imperialrange.com ■ E-mail: imperialsales@imperialrange.com

Imperial Heavy Duty Electric Griddle Series - Thermostat Controlled

Specification #:

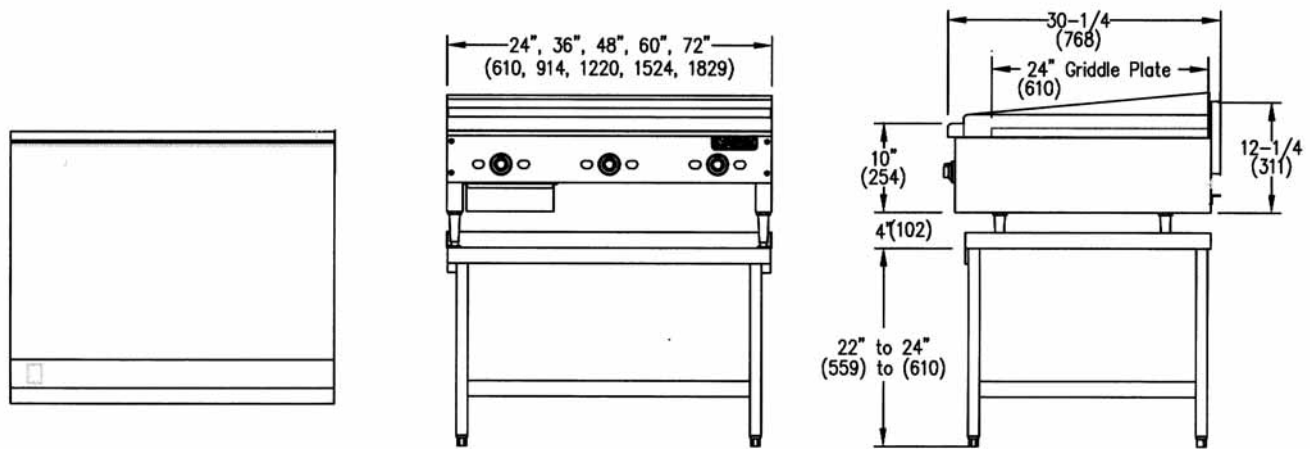

Model#	Griddle Width	Number of Elements	Overall Width	Electric Output (KW)	Ship Weight		Stand Model#	Ship Weight	
					(Kg.)	Lbs.		(Kg.)	Lbs.
ITG-24-E	24" (610)	2	24" (610)	(18)	136	300	ITGS-24	23	50
ITG-36-E	36" (914)	3	36" (914)	(26)	195	430	ITGS-36	32	70
ITG-48-E	48" (1219)	4	48" (1219)	(35)	261	575	ITGS-48	39	85
ITG-60-E	60" (1524)	5	60" (1524)	(18)	328	725	ITGS-60	48	105
ITG-72-E	72" (1829)	6	72" (1829)	(18)	396	875	ITGS-72	62	135

Crated Dimensions: Height =14" (356) Depth = 36" (914) Width: add 2 1/2" (64) to Griddle width.

Standard Exterior Specifications

Front, ledge, grease trough, splash guard and sides shall be stainless steel with welded and finished stainless steel seams. Legs shall be 4" (102) stainless steel with adjustable feet.

Griddle Top Specifications

Griddle plate shall be 1/2" (13) thick, highly polished plate with no breaking-in required. Griddle plate shall be 24" (610) deep. Element shall provide even heating over the entire griddle plate surface, with fast heat-up and recovery. These electric heating elements shall be solid mounted to the bottom of the griddle plate with 1" flat bar. Elements shall be rated at 4 KW per foot of griddle plate. Thermostat shall maintain selected griddle temperature during peak cooking periods. Full width rear flue shall be designed to help distribute heat uniformly across griddle surface.

Unit shall have a stainless steel 4" (102) high tapered splash guard. Grease trough shall be 3 1/2" (89) wide for easy cleaning. Removable grease can shall have a 1 gal. (3.8 L) capacity and a weep hole to indicate when can is full.

Electric Requirements

208 VAC, 3 PH, 60 HZ, 30 AMPS MAX.
240 VAC, 3 PH, 60 HZ, 26 AMPS MAX.
480 VAC, 3 PH, 60 HZ, 14 AMPS MAX.

Clearance

For use only on non-combustible floors. Legs or casters are required for non-combustible floors. Provide 0" clearance from non-combustible surfaces and 8" (203) from combustible surfaces.

Optional Items

- Chrome griddle top
- Stainless steel stands
- 6" (152) casters for equipment stands
- Integrated refrigerated base (see Sizzle 'n Chill specification sheet).

AIA File #:

Imperial Commercial Cooking Equipment

1128 Sherborn Street ■ Corona, CA 92879 ■ 800.343.7790 ■ Ph: 951.281.1830 ■ Fx: 951.281.1879

www.imperialrange.com ■ E-mail: imperialsales@imperialrange.com