

Heavy Duty Range Diamond Series 36" (914) Modular Top Units



Model IHR-4-M shown with optional stand

Heavy Duty Range Features

- Sleek European styling with wide radius ledge and optional high shelf, unique cast aluminum knobs featuring a vylox heat protection grip.
- Stainless steel front, oven door, control panel, landing ledge and kick plate.
- Large 7" (178) stainless steel landing ledge.
- Enclosed front 1 1/4" (32) manifold.
- 6" (152) heavy duty legs, with adjustable feet.
- One year parts and labor warranty.
- AGA and CGA design certified, NSF and CE listed.



All measurements in () are metric equivalents.

Cooktop - Open Burner Features

- Burners are 35,000 BTU/hr (10 KW) with a 7,000 BTU/hr. (2 KW) low simmer feature.
- One-piece venturi base has no gaskets. Venturi slopes to burner creating more efficient heating.
- Cast iron burners are anti-clogging and removable for easy cleaning.
- All stainless steel pilot tubing and solid brass top burner valves.
- Wavy grates create more heat transfer than direct metal-to-metal contact. Heat convects in the waves for continual heat-to-pan action.
- Grates feature flame shaping center tube for more efficient heat transfer.
- Grates are 12" x 14" (305 x 356) sections to easily lift off for cleaning.
- Anti-clogging shield designed in grate protects the pilot from grease and debris.

Cook Top Features - Griddle Top

- 1" (25) thick steel polished griddle plate 36" w x 24" d. (914 w x 610 d).
- One burner every 12" (305), rated at 30,000 BTU/hr (9 kw) ea. Standing pilot for automatic ignition.
- Manual griddle controls or thermostatic griddle controls ("GT36" models).
- Large grease can with one gallon capacity.
- 3 3/4" (95) wide grease gutter.

Cooktop - Hot Top Features

- Two heavy duty polished cast iron tops 18" w x 28" d (457 w x 711 d).
- One burner every 18" (457), rated at 40,000 BTU/hr (12 KW). Standing pilot for automatic ignition.
- Heat tops have manual controls for each burner.

Cooktop - French Top Features

- Circular cast iron ring and cover lift off so that cooking utensils can be placed directly on the intense open flame.
- Temperatures gradually reduce at the rear of each 18" w x 28" d (457 w x 711 d) top for simmering.
- Two removable circular rings are located directly over the burner for sauteing.
- One cast iron ring burner rated at 30,000 BTU/hr. (9 kw) for each 18" (457) section.
- Manual controls for each burner.
- Burner has standing pilot for automatic ignition.
- French top is a heavy casting with a polished surface and heat retaining projections underneath to absorb and defuse heat.

Imperial Commercial Cooking Equipment

1128 Sherborn Street ■ Corona, CA 92879 ■ 800.343.7790 ■ Ph: 951.281.1830 ■ Fx: 951.281.1879
www.imperialrange.com ■ E-mail: imperialsales@imperialrange.com

Imperial Heavy Duty Range Diamond Series - 36" (914) Modular Top Units

Specification #:

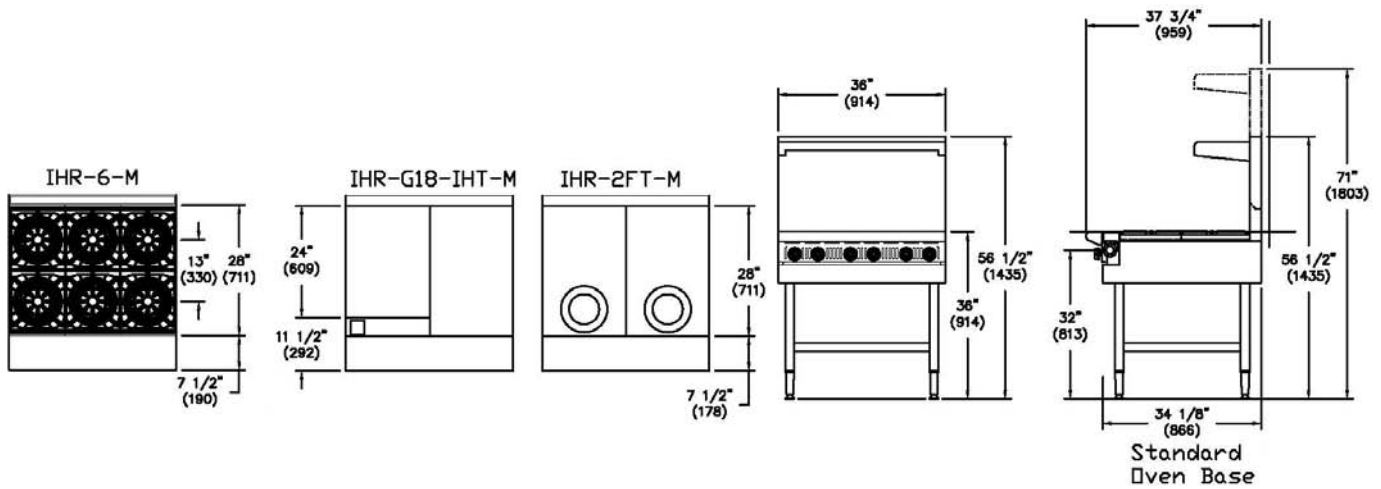

Model#	Description	Width	Depth	Height*	Total BTU	Total (KW)	Ship Wt. (Kg.)	Lbs.
IHR-6-M	Six Open Burners	36" (914)	37 ³ / ₄ " (940)	11" (279)	210,000	(61)	(145)	320
IHR-4-M	Four Open Burners	36" (914)	37 ³ / ₄ " (940)	11" (279)	140,000	(41)	(143)	315
IHR-G36-M	36" (914) Manual Griddle	36" (914)	37 ³ / ₄ " (940)	11" (279)	90,000	(26)	(152)	335
IHR-GT36-M	36" (914) Thermostatic Griddle	36" (914)	37 ³ / ₄ " (940)	11" (279)	90,000	(26)	(152)	335
IHR-2HT-M	Two 18" (457) Even Heat Hot Tops	36" (914)	37 ³ / ₄ " (940)	11" (279)	80,000	(26)	(152)	335
IHR-G18-1HT-M	18" (457) Manual Griddle and 18" (457) Even Heat Hot Top	36" (914)	37 ³ / ₄ " (940)	11" (279)	70,000	(20)	(154)	340
IHR-GT18-1HT-M	18" (457) Thermostatic Griddle and 18" (457) Even Heat Hot Top	36" (914)	37 ³ / ₄ " (940)	11" (279)	70,000	(20)	(154)	340
IHR-G18-2-M	18" (457) Manual Griddle and Two Open Burners	36" (914)	37 ³ / ₄ " (940)	11" (279)	100,000	(29)	(148)	325
IHR-GT18-2-M	18" (457) Thermostatic Griddle and Two Open Burners	36" (914)	37 ³ / ₄ " (940)	11" (279)	100,000	(29)	(148)	325
IHR-2-1HT-M	Two Open Burners and 18" (457) Even Heat Hot Top	36" (914)	37 ³ / ₄ " (940)	11" (279)	110,000	(32)	(153)	337
IHR-1HT-2-M	18" (457) Even Heat Hot Top and Two Open Burners	36" (914)	37 ³ / ₄ " (940)	11" (279)	110,000	(32)	(153)	337
IHR-G24-2-M	24" (610) Manual Griddle and 2 Open Burners	36" (914)	37 ³ / ₄ " (940)	11" (279)	130,000	(38)	(168)	371
IHR-2HT-2-M	Two 12" (305) Even Heat Hot Tops and 2 Open Burners	36" (914)	37 ³ / ₄ " (940)	11" (279)	150,000	(44)	(156)	344
IHR-4-1HT-M	Four Open Burners and 12" (305) Even Heat Hot Top	36" (914)	37 ³ / ₄ " (940)	11" (279)	180,000	(53)	(148)	327
IHR-3HT-3-M	Three Combination Open Burners and 1/2 Even Heat Hot Tops	36" (914)	37 ³ / ₄ " (940)	11" (279)	135,000	(40)	(155)	342
IHR-2FT-M	Two 18" (457) French Tops	36" (914)	37 ³ / ₄ " (940)	11" (279)	60,000	(18)	(151)	333
IHR-RB-M	36" (914) Radiant Broiler	36" (914)	37 ³ / ₄ " (940)	11" (279)	90,000	(26)	(183)	403

*Height to cooking surface. All measurements in () are metric equivalents.

Crated Dimensions: 39" (991) d x 40" (1016) w x 38¹/₂" (978) h.

AIA File #:

Imperial Commercial Cooking Equipment

1128 Sherborn Street ■ Corona, CA 92879 ■ 800.343.7790 ■ Ph: 951.281.1830 ■ Fx: 951.281.1879
www.imperialrange.com ■ E-mail: imperialsales@imperialrange.com