

## Heavy Duty Range Diamond Series 2 Open Burners and 18" (457) Hot Top



Model IHR-1HT-2 shown with stainless steel sides, backguard and shelf

Wavy grate design and center tube for more efficient heat transfer.

### Heavy Duty Range Features

- Sleek European styling with wide radius ledge and optional high shelf, unique cast aluminum knobs featuring a vylox heat protection grip.
- Stainless steel front, oven door, control panel, landing ledge and kick plate.
- Large 7" (178) stainless steel landing ledge.
- Enclosed front 1 1/4" (32) manifold.
- 6" (152) heavy duty legs, with adjustable feet.
- One year parts and labor warranty.
- AGA and CGA design certified, NSF and CE listed.



All measurements in ( ) are metric equivalents.

### Model Numbers

- IHR-2-1HT                       IHR-2-1HT-C

### Cooktop - Open Burner Features

- Burners are 35,000 BTU/hr (10 KW) with a 7,000 BTU/hr. (2 KW) low simmer feature.
- One-piece venturi base has no gaskets. Venturi slopes to burner creating more efficient heating.
- Cast iron burners are anti-clogging and removable for easy cleaning.
- All stainless steel pilot tubing and solid brass top burner valves.
- Wavy grates create more heat transfer than direct metal-to-metal contact. Heat convects in the waves for continual heat-to-pan action.
- Grates feature flame shaping center tube for more efficient heat transfer.
- Grates are 12" x 14" (305 x 356) sections to easily lift off for cleaning.
- Anti-clogging shield designed in grate protects the pilot from grease and debris.
- Pots slide easily across sections and onto ledge.

### Cook Top Features - Hot Top

- One heavy duty polished top 18" w x 28" d (457 w x 711 d).
- One burner every 18" (457), rated at 40,000 BTU/hr (12 KW). Manual controls for each burner.

### Standard Oven Features

- Chef Depth standard oven interior accommodates standard 18" x 26" (457 x 660) sheet pans front-to-back and side-to-side.
- 100% safety pilot. Manual oven shut-off valve.
- Heavy duty thermostat with temperature range from 150°F to 500°F. (65°C to 260°C). Oven controls located on the side in cool zone.
- Porcelainized side, rear and deck for browning.
- Unique baffle above the burner distributes heat flow to provide even cooking temperatures throughout the 40,000 BTU/hr. (12 KW) oven.
- Stainless steel door liner optimizes heat retention.
- Safety valve tubing is stainless steel.

### Convection Oven Features (add suffix C)

- Convection oven has 1/4 hp blower motor.
- Electronic ignition system with single solenoid valve. Direct spark-to-burner with flame rectification.
- Stainless steel door gasket.
- Three position switch for cooking or cool down.

### Imperial Commercial Cooking Equipment

1128 Sherborn Street ■ Corona, CA 92879 ■ 800.343.7790 ■ Ph: 951.281.1830 ■ Fx: 951.281.1879  
www.imperialrange.com ■ E-mail: imperialsales@imperialrange.com

# Imperial Heavy Duty Range - 2 Open Burners and 18" Hot Top

Specification #:

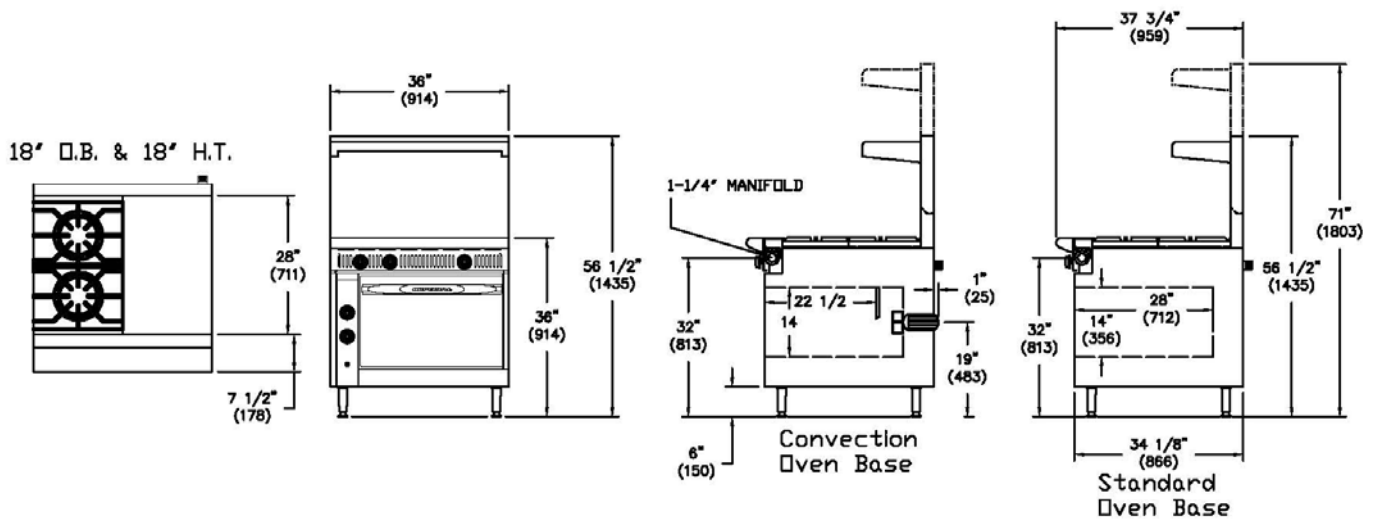

Model#	Hot Top	Description	Burners	Oven	Width	Depth	Height*	Total BTU	Total (KW)	Ship Wt. (Kg.)	Lbs.
IHR-2-1HT	18" (457)	2 Open	Standard	36" (914)	37 1/2" (953)	36" (914)	150,000	(44)	(272)	600	
IHR-2-1HT-C	18" (457)	2 Open	Convection	36" (914)	37 1/2" (953)	36" (914)	145,000	(43)	(299)	660	

\*Height to cooking surface. All measurements in ( ) are metric equivalents.

**Crated Dimensions:** 39" (991) d x 40" (1016) w x 38 1/2" (978) h.

## Standard Exterior Specifications

Front oven door, wide radius landing ledge, control panel and kick plate shall be constructed of stainless steel with welded and finished stainless steel seams. Base shall be 10 gauge steel. Control knobs shall be cast aluminum with vylox grip. Stainless steel 6" (152) legs shall have a 2 1/2" (64) diameter with adjustable feet and a 5/8" (16) mounting plate.

## Range Tops Specifications

Open burners shall have 35,000 BTU/hr. (10 KW) lift-off PyroCentric™ burner heads with no gaskets or screws. Each burner shall have one standing pilot for each burner. Unit shall have a removable one piece drip tray. Top grates shall be in 14" x 18" (356 x 457) lift-off sections, constructed of heavy-duty cast iron. Cast-in bowl shall direct heat upward. Top grate design shall include an integrated pilot shield.

## Hot Top Specifications

Hot top burner shall be 40,000 BTU/hr. (12 KW) "U" type located every 18" (457) for even cooking. Burners shall be individually controlled. Each burner shall have one adjustable gas valve and one standing pilot. Aeration baffles shall be installed between burners and a full width rear flue shall be included to ensure a uniform surface temperature. Hot top plate shall be 1" (25) thick, highly polished plate with no breaking-in required. Hot top plate shall be 28" (711) deep x 18" (457) wide.

## Standard Oven Specifications

Oven shall have 12 gauge construction with welded front frame. It shall be fully insulated with non-sag fiberglass. The oven interior sides, rear and deck shall be porcelainized for easy cleaning and better browning. Door lining shall be stainless steel. Oven burner shall provide 40,000 BTU/hr. (12 KW) output. Unique baffle above the burner shall distribute heat flow to provide even cooking temperatures throughout the oven. Unit shall have a 100% safety pilot. One heavy duty locking chrome plated rack shall be included. Thermostat controls shall be adjustable from 150°F to 500°F (65°C to 260°C). Oven interior dimensions shall be 26 1/2" w x 28" d x 14" h (673 w x 711 d x 356 h) to accommodate sheet pans front-to-back.

## Convection Oven Specifications

Oven shall have 12 gauge construction with welded front frame. It shall be fully insulated with non-sag fiberglass. The oven interior sides, rear and deck and shall be porcelainized. Oven burner shall provide 35,000 BTU/hr. (10 KW) output. Oven shall have an electronic ignition system with single solenoid valve and direct spark-to-burner with flame rectification. Thermostat controls shall be adjustable from 150°F to 500°F. (65°C to 260°C). Unit shall have a three position switch for cooking or cool down, a burner "ON" indicator light and one hour manual timer. Fan shall shut off automatically when door is open. Oven interior dimensions shall be 26 1/2" w x 22 1/2" d x 14" h (673 w x 572 d x 356 h). Three heavy duty locking chrome plated racks shall be included.

## Gas

Manifold pressure is 5.0" W.C. for natural gas or 10.0" for propane gas. Manifold size 1 1/4" NPT. Specify type of gas and elevation if over 2000 ft. (610 m).

## Clearance

For use only on non-combustible floors. Legs or casters are required for non-combustible floors; or 2" (51) overhang is required when curb mounted. Provide 0" clearance from non-combustible surfaces and 8" (203) from combustible surfaces.

## Optional Items

- Extra chrome rack
- Reinforcement channels for mounting cheesemelter/salamander
- Stainless steel single or double shelves (specify style)
- Storage base unit (add suffix "-XB")
- Gas pressure regulator
- Rear gas connection
- Gas shut off valve (specify size)
- Quick disconnect and flexible gas hose
- 6" (152) casters

AIA File #:

## Imperial Commercial Cooking Equipment

1128 Sherborn Street ■ Corona, CA 92879 ■ 800.343.7790 ■ Ph: 951.281.1830 ■ Fx: 951.281.1879  
www.imperialrange.com ■ E-mail: imperialsales@imperialrange.com