

Range Match Spreader Cabinets



Model IR-18-SPR
shown with optional stainless steel door

Model Numbers

- IR-12-SPR
- IR-18-SPR
- IR-24-SPR
- IR-36-SPR

Spreader Cabinet Features

- Stainless steel work surface.
- Provides additional working space between ranges.
- Available in 12" 18", 24" and 36" widths (305, 457, 610, and 914).

All measurements in () are metric equivalents.

Range Match Features

- Stainless steel front, sides, backguard, shelf and landing ledge.
- Welded stainless steel seams.
- Large 5" (127) stainless steel landing ledge.
- 6" (152) heavy duty legs with adjustable feet.
- One year parts and labor warranty.
- NSF and CE listed.



Imperial Commercial Cooking Equipment

1128 Sherborn Street ■ Corona, CA 92879 ■ 800.343.7790 ■ Ph: 951.281.1830 ■ Fx: 951.281.1879
www.imperialrange.com ■ E-mail: imperialsales@imperialrange.com

Imperial Range Match Spreader Cabinets

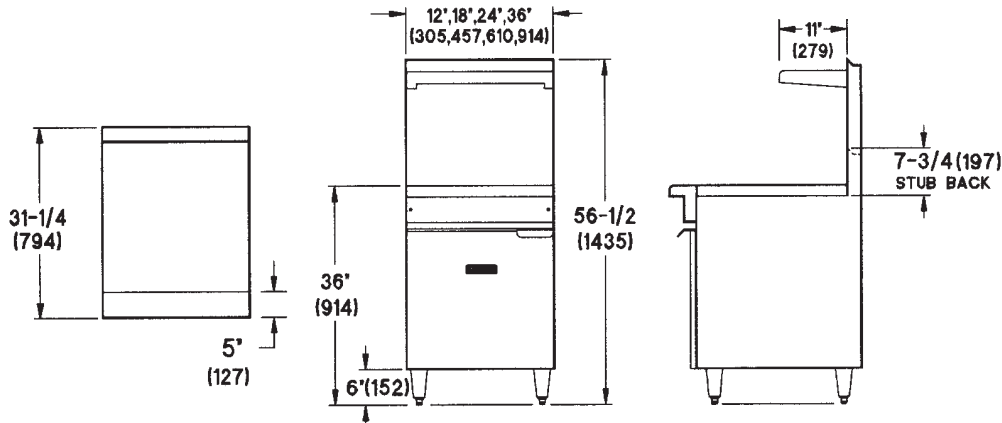

Specification #:

Model#	Description	Ship Weight	
		(KW)	Lbs.
IR-12-SPR	12" (305) Spreader Top and Cabinet Base	(68)	150
IR-18-SPR	18" (457) Spreader Top and Cabinet Base	(72)	160
IR-24-SPR	24" (610) Spreader Top and Cabinet Base	(88)	195
IR-36-SPR	36" (914) Spreader Top and Cabinet Base	(95)	210

Crated Dimensions: Add 2" (51) to overall w x 35" (889) d x 39" (991) h.

All measurements in () are metric equivalents.

Standard Exterior Specifications

Front, sides, landing ledge, control panel, backguard with shelf and kick plate shall be constructed of stainless steel with welded and finished stainless steel seams. Chrome plated 6" (152) legs shall have adjustable feet.

Overall dimensions shall be as follows:

- IR-12-SPR 12" w x 31¹/₄" d x 56¹/₄" h (305 x 794 x 1429)
- IR-18-SPR 18" w x 31¹/₄" d x 56¹/₄" h (457 x 794 x 1429)
- IR-24-SPR 24" w x 31¹/₄" d x 56¹/₄" h (610 x 794 x 1429)
- IR-36-SPR 36" w x 31¹/₄" d x 56¹/₄" h (914 x 794 x 1429)

Optional Items

- Reinforcement channels for mounting cheese melter and salamander
- Stainless steel stub back
- Stainless steel cabinet door and intermediate shelf
- Electric Bain-Marie with stainless steel door and faucet
- Cut out to accommodate sink
- 6" (152) casters

AIA File #:

Imperial Commercial Cooking Equipment

1128 Sherborn Street ■ Corona, CA 92879 ■ 800.343.7790 ■ Ph: 951.281.1830 ■ Fx: 951.281.1879

www.imperialrange.com ■ E-mail: imperialsales@imperialrange.com